

All electrical installations and components in blender area are Class 1, Div 1, Group D

Available Option:
Gas Density Monitor, skid-mounted; measures NatGas/Air MixGas properties and displays Calorific Value, Wobbe Index, and Specific Gravity of MixGas at Operator Interface in Master Control Panel.

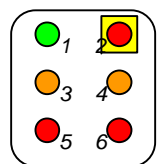
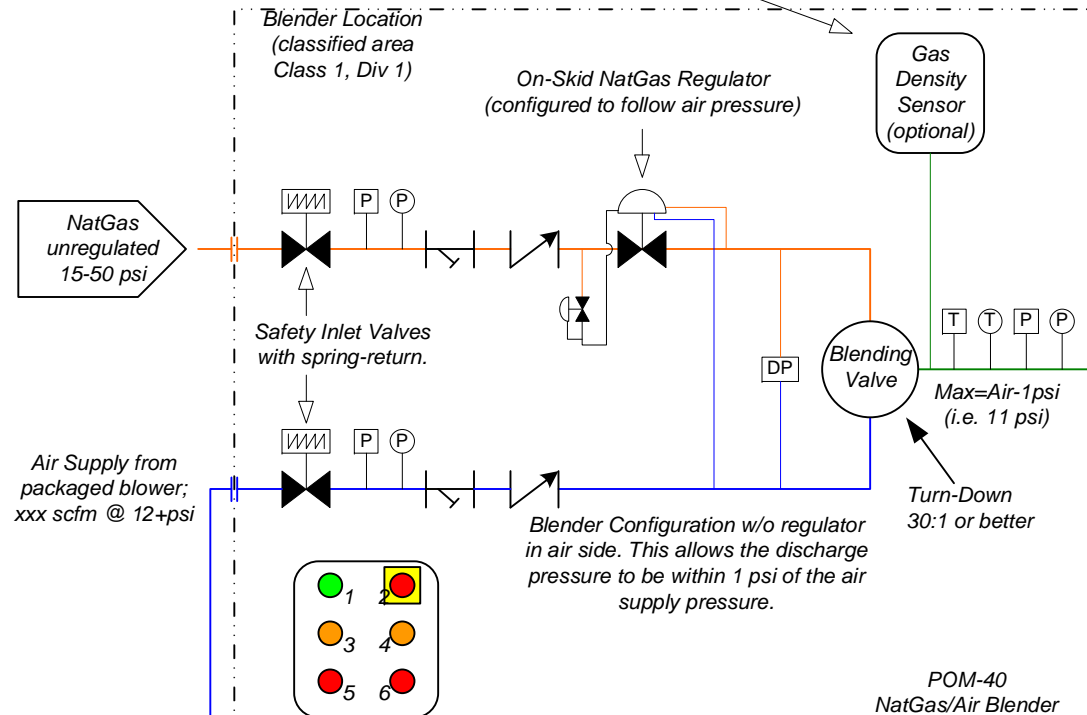

- Skid-Mounted Control Panel
- 1 - Control Power ON/OFF
 - 2 - ESD Mushroom Button
 - 3 - Inlet Valves Open/Close
 - 4 - Blender Start/Stop
 - 5 - Alarm Silence
 - 6 - Alarm Reset
- NOTE: Blender can be operated through push buttons at local Start/Stop Station, or through the touch screen in the Master Control Panel.
- [P] Pressure Transmitter
 - [P] Pressure Gauge
 - [T] Temperature Transmitter
 - [T] Temperature Gauge

Blender Location will be defined as Classified Area (Indoor or Outdoor)

Non-Classified Outdoor Location

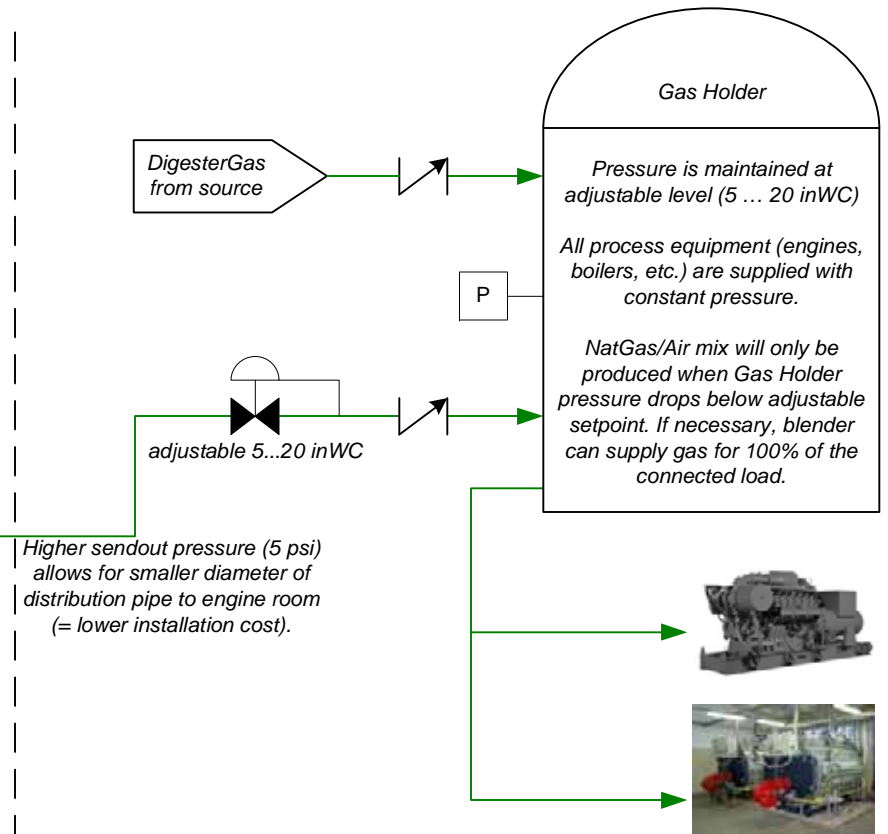
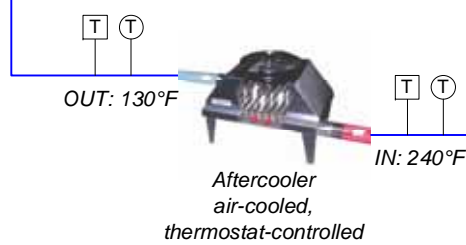

Engine Room or other non-classified area

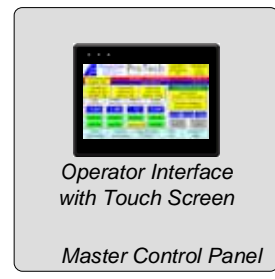

NOTE: Remote access for monitoring and control via Ethernet is standard. UL 508a stamp for panel available.

#	DATE	REVISION DESCRIPTION	DRAWN	APPRV'D
		Alternate Energy Systems, Inc.		
	DATE: 14-July-10	SCALE: NTS	DRAWN BY: WHD	APPROVED BY: n/a
	TITLE: DigesterGas Backup/Augmentation System - GasHolder Example			
	REVISION NUMBER: Revision # 0	DRAWING FILE: DigesterGas Replacement Blender Block Diagram.vsd		